

Product Information Vertical blinds

Suitable as view and sun protection

The turnable slats enable a variable control of shielding and transparency

For private areas, and in offices, doctor's practices, sales rooms and public institutions

Design element due to lightweight, colour-coordinated design of the slats

Convenient operation



Models

All types are available in different versions.

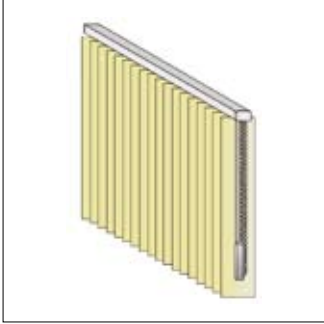

Standard-facility
with free-hanging slats

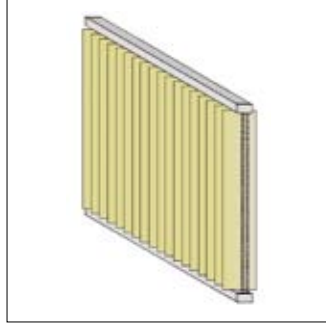

Guided at the top and the bottom
with spring-tensioned slats between two rails

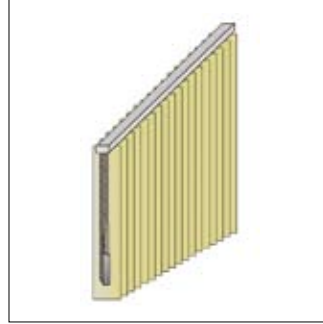

Slope-facility
(Fig. lower side on the left)

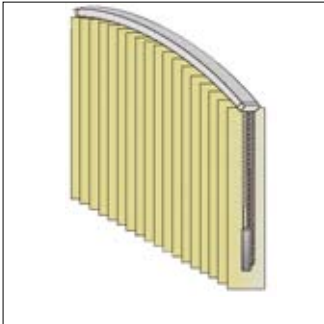

Vertically bent bay facility
with vertex

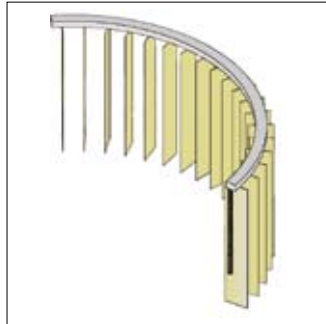

Horizontally bent facility

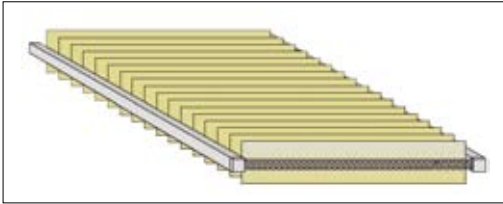

Horizontally mounted ceiling facility
with spring-tensioned slats between two rails

Limit sizes

Model, Type	Type of operation	min. width (mm)	max. width (mm)	min. height (mm)	max. height (mm)	max. surface (m ²)
10, 11, 12, 13	KZ, SZ, EL EZ	350 350	7000 4500	500 500	5000 5000	35 22,5
20	KZ, SZ, EL	350	4000	500	5000	20
40, 41, 60, 61	KZ, SZ, EL	350	7000	500	5000	35
80, 81, 82, 90, 91, 92, 93, 94	KZ, SZ, EL	350	5600	500	5000	28
25	KZ, SZ, EL	350	4500	500	2000	9

Types of operation

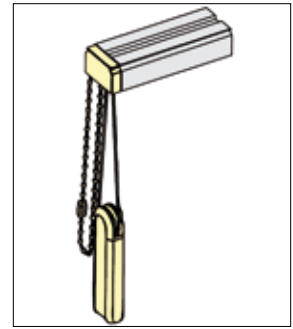

Cord / chain

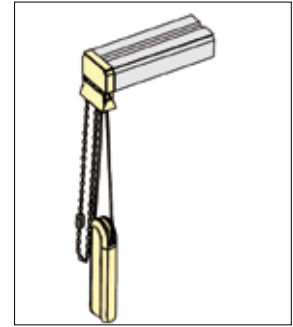

Cord / chain with cord brake

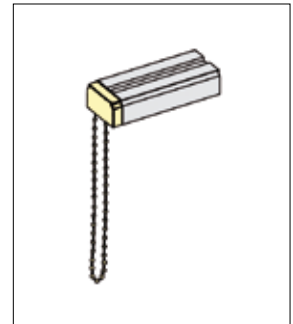

Mono drive

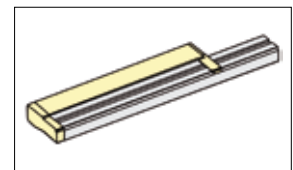

Electric drive 230V

KZ = Cain
SZ = Cord
EL = Electric drive
EZ = Continuous draw-cord

Qualified company:

Head Office:
HELLA Sonnen- und Wetterschutztechnik GmbH
A-9913 Abfaltersbach 125
T. +43 (0)4846 / 65 55-0
F. +43 (0)4846 / 65 55-134
E: office@hella.info

www.hella.info